

## Joint Opinion of German and Austrian industry associations on the proposed Articles 4 and 4a MDR

23<sup>th</sup> February 2026

### Analysis of the proposed provisions

The current version of Article 4 of the Regulation (EU) 2017/745 on medical devices (MDR) includes a legally binding procedure for the determination of the regulatory status of a product. Such a procedure has been missing under the former Directive 93/42/EEC on medical devices and therefore it is an appreciated improvement. As no procedure according to the current Article 4 MDR has been conducted yet, it remains unclear why the European Commission suggests an amendment to this provision.

The reform proposal appears to seek to legally entrench the so-called Helsinki procedure, a decision-making mechanism characterized by limited transparency and an insufficient scientific basis.

The formally structured procedure proposed in the revised version of Articles 4 and 4a is highly questionable, as a decision on the regulatory status of a product initiated by a single competent authority becomes decisive unless another authority of a Member State raises a substantiated objection.

Particularly critical is the new proposed provision in Article 4(3), which allows Member States to adopt measures affecting the regulatory status of products that already bear the CE marking. This significantly relativizes the principle of free movement of goods enshrined in Article 24 MDR, the Blue Guide as well as Articles 34 and 36 TFEU and undermines legal certainty and legitimate expectations. In the absence of clearly defined substantive criteria, procedural safeguards and effective mechanisms for the protection of vested rights, there is a substantial risk that individual national decisions may de facto undermine EU-wide market access.

Moreover, the specific wording of the new provisions raises fundamental questions regarding the role and legal effect of the expert panels referred to in the proposed Article 106. While their opinions are to be “given the utmost consideration” by the competent authorities, they are not legally binding. Consequently, the final decision on regulatory status remains discretionary. The risk of divergent assessments under identical EU-wide conditions is therefore not fully eliminated, particularly since there is no obligation to apply the procedures set out in proposed Articles 4 and 4a. As a result, the intended strengthening of legal certainty is unlikely to be achieved in practice. In addition, unresolved issues remain regarding technical coverage and the long-term availability of sufficient expertise, especially for complex demarcation and classification questions. In this context, the mandatory involvement according to proposed Article 4(2) of other European bodies (e.g. EMA, ECHA or EFSA) does not remedy the structural deficit resulting from the lack of systematic involvement of independent scientific, technical and industry expertise, which may lead to isolated and inconsistent outcomes.

Proposed Article 4(6) MDR grants the European Commission the power to specify, by means of implementing acts, the procedure, including binding deadlines, for the coordination and demarcation mechanisms referred to in proposed Articles 4(1) to (4) and proposed Article 4a. While this allocation of powers would be welcome in principle, the general procedural framework already reflects key elements of the Helsinki procedure, which has been subject to justified criticism. Moreover, there is a risk that, despite formal legal restructuring, the demarcation process will continue in practice to be marked by delays, isolated positions and divergent national approaches.

### Important assumptions

The following assumptions are necessary to ensure legal certainty for manufacturers, to enable their willingness to place devices on the market, and to guarantee the availability of devices on the Union market:

- Apart from a decision of the Commission adopted by means of an implementing act, only the competent authority of the Member State in which the manufacturer has its registered place of business should be empowered to determine the regulatory status of a product of that manufacturer (see Annex 1).
- The free movement of CE-marked medical devices must be safeguarded, as guaranteed by Article 24 MDR, the Blue Guide as well as Articles 34 and 36 TFEU.
- National authorities responsible for market surveillance in Member States where a CE-marked device is merely distributed should be empowered to carry out market surveillance activities in accordance with Article 93 ff. MDR. Any concerns regarding the correct regulatory status of a CE-marked device should be referred to the Commission by means of a duly substantiated request after opinion of an expert panel or to the Member State in which the manufacturer has its registered place of business (see Annex 2).
- Expert panels should demonstrate proven and up-to-date clinical, scientific, technical or regulatory expertise in the field of medical devices, as well as impartiality, objectivity and transparency. For the determination of the regulatory status of products, it must be ensured that the expert panel has access to all relevant information necessary to fulfil its tasks. This includes, in particular, information provided by the manufacturer and, if applicable, the manufacturers of equivalent CE marked devices, who possesses the most comprehensive knowledge of the products concerned.
- The expert panel should also assess whether a previous determination of a product, and the underlying reasoning of such a determination by authorities or administrative or civil courts, remains applicable under the current and amended Union legislation.

### Concrete recommendation

The signing associations propose the complete deletion of the proposed Article 4 and a rewording of the proposed Article 4a as follows:

#### Article 4a

Opinion on and determination of the regulatory status of a product

1. (*proposed Article 4a(1)*) A competent authority, a notified body, a manufacturer, a developer of a product or the Commission may submit a substantiated request for an opinion from an expert panel referred to in Article 106 on the question whether a specific product, or category or group of products, falls within the definitions of 'medical device' or 'accessory for a medical device', or whether a product falls within the scope of Annex XVI or is an accessory for a product listed in that Annex. Where, in such a request, the requester considers that the product in question is a device, the request shall also specify the proposed classification of the device in accordance with Article 51 and Annex VIII.

2. (*proposed Article 4(2)*) Where a competent authority of a Member State, after having performed an evaluation in accordance with Article 94, considers that a product that is CE

marked in accordance with Article 20, does not fall within the scope of this Regulation, it shall consult **the competent authority of the Member State where the manufacturer has its registered place of business and the manufacturer** ~~other Member States~~ regarding its ~~envisaged measure determining the~~ **justification** on the regulatory status of the product in question, **before submitting a substantiated request for an opinion of an expert panel as referred to in paragraph 1.**

3. *(proposed Article 4(3))* ~~The Member States~~ **expert panel** shall ensure an appropriate level of consultation of the relevant competent authorities of the Member States in the fields of in vitro diagnostic medical devices, medicinal products, substances of human origin (SoHO), biocides, food products, cosmetics or other products subject to Union legislation, where the determination of whether a product has the regulatory status of a device involves aspects concerning the borderline with any of those types of products. If that is the case, ~~Member States~~ **the expert panel** shall also ensure an appropriate level of consultation of the relevant advisory or regulatory bodies established in the relevant Union legislation, such as the European Medicines Agency (EMA), the SoHO Coordination Board, the European Chemicals Agency (ECHA) and the European Food Safety Authority (EFSA). **The expert panel shall consult the notified body, the manufacturer, the manufacturer(s) of equivalent CE marked medical devices, the developer of the concerned product.**

4. *(proposed Article 4a(2))* The expert panel shall provide its opinion **within 30 days** ~~without undue delay~~. The requester shall ~~give utmost consideration to~~ **accept** the opinion of the expert panel.

*(proposed Article 4a(4))* ~~4. This Article shall not apply where within the framework of another Union legislation the regulatory status of the product, or category or group of products, concerned has been determined as falling within the scope of that other Union legislation or where a procedure for the determination of the regulatory status is ongoing within the framework of another Union legislation.~~

5. *(proposed Article 4(5))* ~~The results of the coordination activities of the competent authorities in accordance with this Article and~~ The opinions of the expert panel delivered in accordance with paragraph 4 of this Article ~~and Article 4a(2)~~ shall be made publicly available, without disclosing any confidential information as referred to in Article 109.

**6. The requirement to publish any opinion of an expert panel pursuant to paragraph 5 shall not apply in the case of innovations with no equivalent CE marked medical devices in the market in order to protect the intellectual property of the developer of such innovations.**

7. *(proposed Article 4a(3))* Having regard to the expert panel opinion referred to in paragraph ~~4 2 or in Article 4(4)~~, a ~~Member State~~ **requester as referred in paragraph 1** may submit a substantiated request to the Commission to determine whether a specific product, or category or group of products, falls within the definitions of 'medical device' or 'accessory for a medical device', or whether a product falls within the scope of Annex XVI or is an accessory for a product listed in that Annex.

The Commission shall decide on the substantiated request of the ~~requester Member State or on its own initiative~~, by means of implementing acts, which shall be adopted in accordance with the examination procedure referred to in Article 114(3).

The Commission may ask the expert panel for clarifications or refer the opinion back to the expert panel for further consideration, including in cases where a Member State's substantiated request raises new questions of a scientific or technical nature.

## Annex 1: Determination of the regulatory status of a product

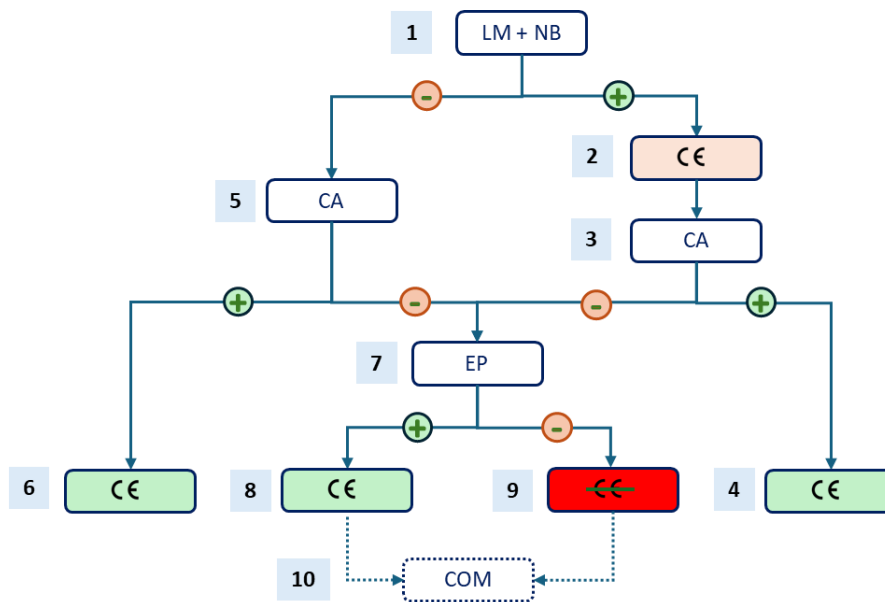

1. Is there consensus between LM and NB that the product qualifies as a medical device under MDR?
2. Answer to question 1 is yes: legal basis for the CE marking
3. Eudamed registration by the LM and release by the CA
4. Release by the CA: legal basis for the CE mark and protected free movement of goods in the EU
5. Answer to question 1 is no: substantiated request to the CA
6. Confirmation of the CA that the product qualifies as medical device: legal basis for the CE marking and protected free movement of goods in the EU (no further EUDAMED impact on the determination of the regulatory status as a device)
7. No release of the EUDAMED registration and no confirmation of the regulatory status as a device: substantiated request to the EP by CA, NB or LM
8. Confirmation of the regulatory status as a medical device by the EP: legal basis for the CE marking and protected free movement of goods in the EU
9. No confirmation of the regulatory status as a medical device by the EP: the CA is empowered to deny the regulatory status as a device, consequently no CE marking
10. Provided that a harmonized European decision is required (not a mandatory step): the COM is empowered to decide about the regulatory status of the product by means of an implementing act taking into account the EP opinion

Abbreviations: LM – Legal Manufacturer · NB – Notified Body · CA – Competent Authority of the Member State in which the LM has its registered place of business · EP – Expert Panel · CE – regulatory status as a device confirmed

## Annex 2: Market surveillance / concerns on the regulatory status of CE marked devices

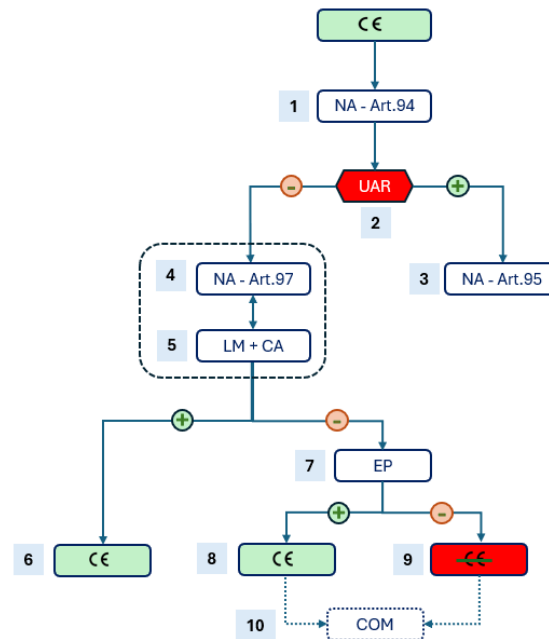

1. Concerns of a NA in terms of the correct regulatory status of a CE-marked device
2. Assessment of an unacceptable risk of the product
3. NA is empowered to implement appropriate measures to control or stop the UAR – independent from the determination of the regulatory status of the product
4. No UAR; an assumed wrong CE marking affects the protected free movement of goods and can only be brought to an end by the LM and the CA; local measures against the marketing are not proportionate prior to the harmonized legally binding determination of the regulatory status
5. Request for confirmation of the regulatory status of the CE-marked device to LM/CA; such a request should include the LM/CA of equivalent or similar CE-marked devices
6. Consensus between NA and LM/CA on the regulatory status of the product as a device; no further measures for the national marketing of the CE-marked device
7. No consensus between NA and LM/CA on the regulatory status of the product as a device; substantiated request to the EP by CA or LM
8. Confirmation of the regulatory status as a medical device by the EP: legal basis for the CE marking and protected free movement of goods in the EU
9. No confirmation of the regulatory status as a medical device by the EP: the CA is empowered to deny the regulatory status as a device, consequently no CE marking
10. Provided that a harmonized European decision is required (not a mandatory step): the COM is empowered to decide about the regulatory status of the product by means of an implementing act taking into account the EP opinion

Abbreviations: CE – regulatory status as a device confirmed · NA – National Authority for market surveillance activities · UAR – Unacceptable Risk · LM – Legal Manufacturer · CA – Competent Authority of the Member State in which the LM has its registered place of business · EP – Expert Panel · COM – European Commission